

Installation Instructions

*Important information about your
new a/c system.*

*Please read the following directions prior to
installing this a/c system.*

*1980-1987 Chevrolet Trucks
Including: M-1008 and M-1009 Trucks*



Nostalgic AC Parts
"Keeping Your Classics Cool"

◆ Contact us by email or phone if you need any assistance or information regarding this a/c system.

888-977-8889
Sales@nostalgicairparts.com

Important information about your system, and warranty

- ➔ DO NOT ADD ANY OIL TO ANY PART OF THE SYSTEM.
- ➔ DO NOT USE THE SIGHT GLASS TO CHARGE THE SYSTEM.
- ➔ DO NOT OVERCHARGE THE SYSTEM.

This Kit is designed to work with R134a refrigerant, not any other refrigerant (freon). The system has been designed and tested using R134a refrigerant. The systems performance with this freon was as expected. Vent temperature of 37-45 F Degrees, and a high side pressure reading at 200-220psi.

The system should not exceed 250psi on the high side, and the low side will stabilize if all is installed correctly.

WE NEED THE HIGH SIDE GAUGE READING IN ORDER TO HELP WITH ANY PROBLEMS.

The system needs to be evacuated for maximum performance. The system will take 1.50 lbs of R134a refrigerant, or two cans. You want the high side to be 200-220psi when the system is on and the vehicle is idle.

DO NOT ADD DYE TO CHECK THE SYSTEM. WE HAVE HAD PROBLEMS WITH THE EXPANSION VALVES GETTING CLOGGED.

If you have a problem with the system we ask to call before diagnosing or changing any parts. We can fix problems easier if the system is not tampered with.

If you have a warranty claim you need to call prior to shipping any parts back.

OUR POLICY IS TO GET THE OLD PART BACK PRIOR TO SHIPPING ANY NEW PARTS OUT.

We are not responsible for the following:

Clogged expansion valve from too much oil, or dye

Cracked compressors from improper installation

Compressor with broken valves from overcharging of oil or refrigerant

Burned up clutches from too high of head pressure

We will be here to serve you seven days a week by phone and / or email
Please contact us if you need assistance.

888-977-8889

The Nostalgic AC Parts team would like to thank you for your recent purchase of a complete a/c kit for your car or truck. There are a few steps that must be followed in order for your a/c system to operate properly.

- The **HIGH SIDE** gauge reading should not exceed 220 PSI. We **MUST** have the **HIGH SIDE** gauge reading if you need any assistance in correcting a potential problem.
- If you purchased the a/c compressor from **NAC**, **DO NOT ADD ANY OIL, DYE, LEAK SEALANTS, OR OTHER ADDITIVES TO ANY PART OF THE SYSTEM**. If oil is required NAC will provide an additional sheet with directions on filling the system with oil.
- Be sure you have the correct pulleys for the engine prior to installing the kit. Pulleys are not included unless specified when the kit is ordered.
- Insulation is very important. Be sure to insulate the firewall and floorboard prior to installing the evaporator unit. It is very important to insulate the floor and firewall behind the evaporator unit.
- There should be adequate airflow from the radiator fan, and a sufficient amount of room between the condenser and radiator. Make sure the **CONDENSER HAS A TUNNEL EFFECT OF AIRFLOW THAT FLOWS THROUGH THE CONDENSER AND RADIATOR**. Foam can be put in between condenser and the radiator edges to achieve a proper airflow effect. There should be ¼” to 1” gap in between the radiator and condenser. **EFFECTS OF INADEQUATE AIRFLOW:** the compressor may act like it is “locking up”; warm air only from the vents, overheating of the engine, high head pressure, air blows cold at idle and blows warm while driving, and more.
- Find the proper flow of the water prior to installing the heater control valve. Water should be turned off prior to entering the evaporator / heating unit. It should only be turned off when the heat is needed. If you are experiencing warm air out of the evaporator check the compressor low side fitting. If it is ice cold then the heater valve is not hooked up properly.
- **DO NOT USE THE SIGHT GLASS!** The system should be charged with R-134a ONLY. If you do not follow this instruction your warranty may be void and you may not be eligible for technical assistance. **EFFECTS OF OVERCHARGING:** Compressor is “noisy”, engine overheating, warm air only from the vents, and more.
- If a problem exists after checking all these conditions you may call or email for technical assistance. **IF YOU DO NOT HAVE THE HIGH SIDE GAUGE READING WE WILL NOT BE ABLE TO ASSIST YOU IN FIXING THE PROBLEM.**

Parts Checklist

CK-8087CHPU / CK-8386M

<input type="checkbox"/> COMPRESSOR	PN: 15-5001
<input type="checkbox"/> CONDENSER	PN: 44-1425
<input type="checkbox"/> STANDARD ORING DRIER	PN: 4-1000
<input type="checkbox"/> DRIER STRAP	PN: 999-1002
<input type="checkbox"/> CONDENSER MOUNT KIT	PN: CS1000
<input type="checkbox"/> HIGH LOW PRESSURE SWITCH	PN: 119-9900
<input type="checkbox"/> R-134a HOSE KIT	PN: HK-920
<input type="checkbox"/> COMPRESSOR MOUNT KIT (ENGINE SPECIFIC)	PN: _____
<input type="checkbox"/> EVAPORATOR KIT	PN: ID-240
<input type="checkbox"/> FRESH AIR RESTRICTOR	PN: P-468
<input type="checkbox"/> FRESH AIR RESTRICTOR	PN: P-469
<input type="checkbox"/> A/C CONTROLS / VENT PANEL	PN: P-471
<input type="checkbox"/> DASH PANEL WITH VENTS	PN: 5072
<input type="checkbox"/> EVAPORATOR PARTS BAG	PN: 77-4024

77-4024 IS LOCATED IN THE EVAPORATOR KIT BOX

Parts included in 77-4010:

77-9402 Drain tube two feet
 5086 Drain tube Tee
 5088 Drain Tube elbow
 G101 Grommets x 2
 Self tapping screws
 Screws with nuts
 2.5" duct hose x 6 feet
 2" duct hose x 4 feet
 5022 Vent x 1
 5023 Vent x 1
 Cork tape

KIT DIRECTIONS

Checked by _____

*This checklist serves as a reference of all the parts included with this kit.

STEP ONE

Installing the Evaporator unit:

- 1) An in dash a/c unit mounts up behind the dash. The glove box will need to be slightly modified to fit correctly.
- 2) Before you begin the installation disconnect the battery.
- 3) All of the hardware removed for this installation will need to be retained; it is reused to reassemble the truck.
- 4) Remove the steering column cover, the instrument cluster (panel) and the dash pad. If your truck has a speaker in the center or right side remove it also.
- 5) Remove the glove box.
- 6) Remove two (2) bolts from lower right dash brace and the 5/16" bolt from the center dash brace.
- 7) On some models earlier than 10/1983 you will need to install the block off fresh air port on the passenger side of the heater housing. Wedge the plastic piece in between the door and the heater opening.
- 8) On some models older than 10/1983, from the engine side of the firewall, remove the heater blower plenum. Seal off the fresh air passage between the heater core and heater plenum with the plastic plate provided. Secure the plate with two (2) screws that are provided. Seal the seam with the foam strip provided. Reinstall the blower plenum. NOTE: On some models there is a fresh air door on the passenger side of the heater blower plenum. If this door is present you will skip mounting the block off plate.

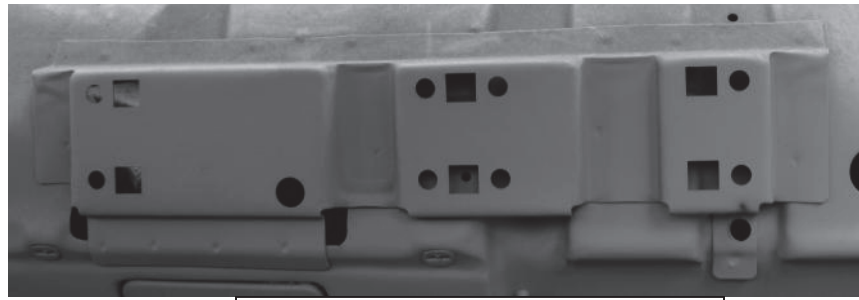

Figure 1.1



Figure 1.2

- 9) If the truck is an M-1008 or an M-1009 you may need to cut the metal brace on the face of the dash board to install the a/c.
- 10) If the vehicle had a depression in the metal, dash above the center louver opening you will need to trim as shown. Figure 1.3.
- 11) The evaporator will be mounted without the blower assembly attached. The evaporator slides behind the dash. The large opening will line up with the large opening in the in the metal dash.
- 12) The small bracket on the front of the unit near the rectangle vent outlet is screwed into the face of the dash. Use the #6 3/8 screw to attach this bracket. A 1/8" pilot is recommended. Figure 1.4



Dash Brace in Military Vehicles



Figure 1.3

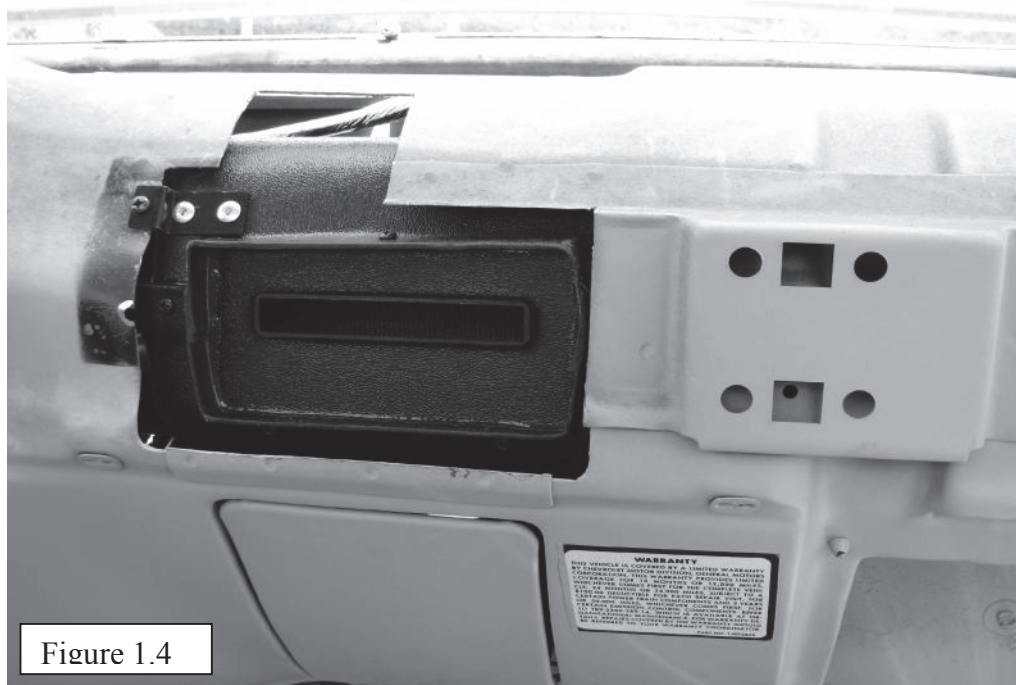
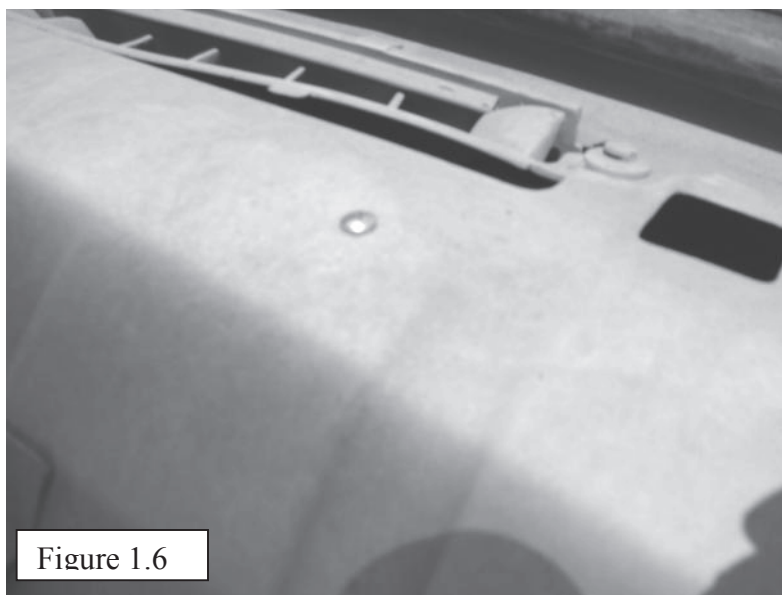
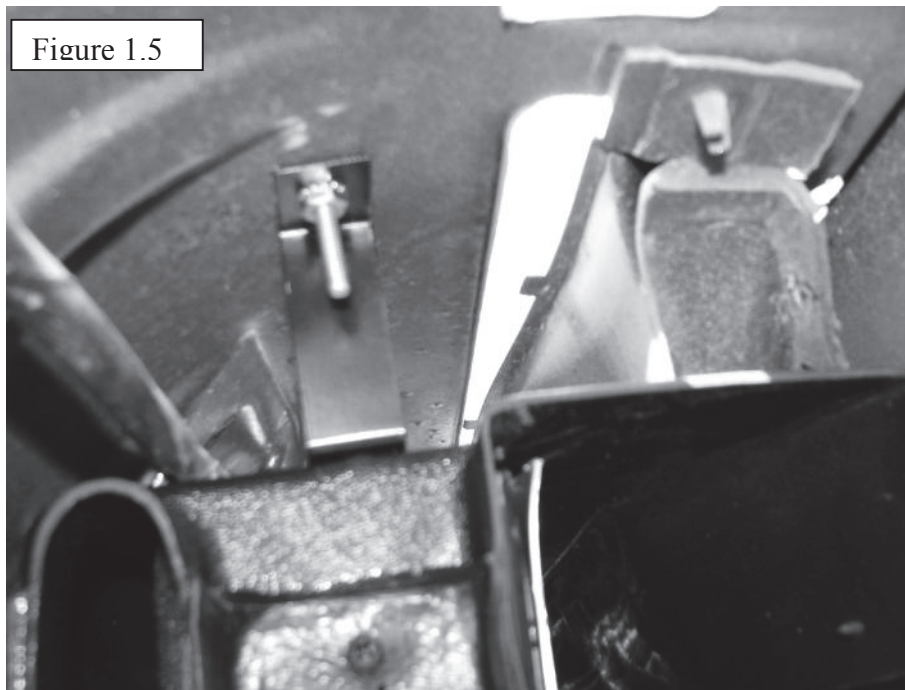
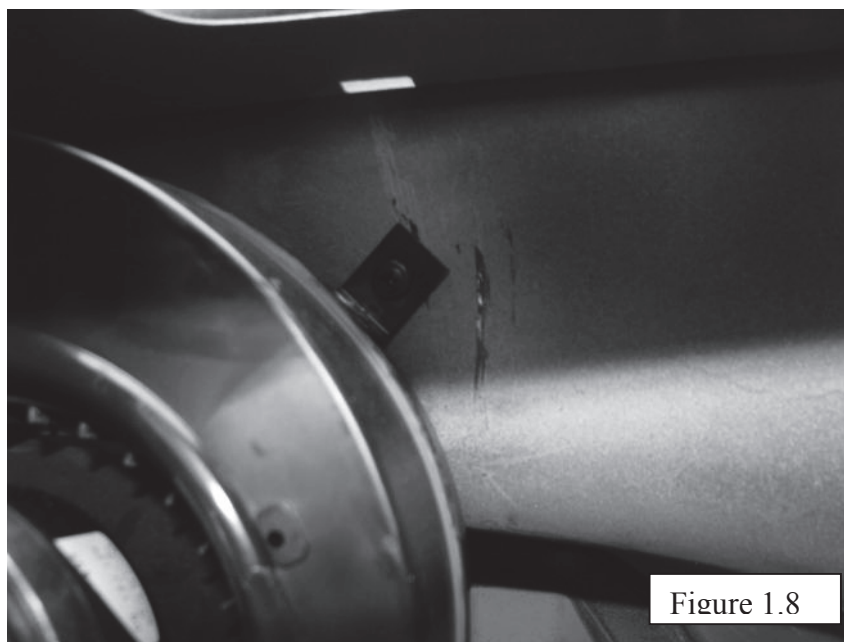
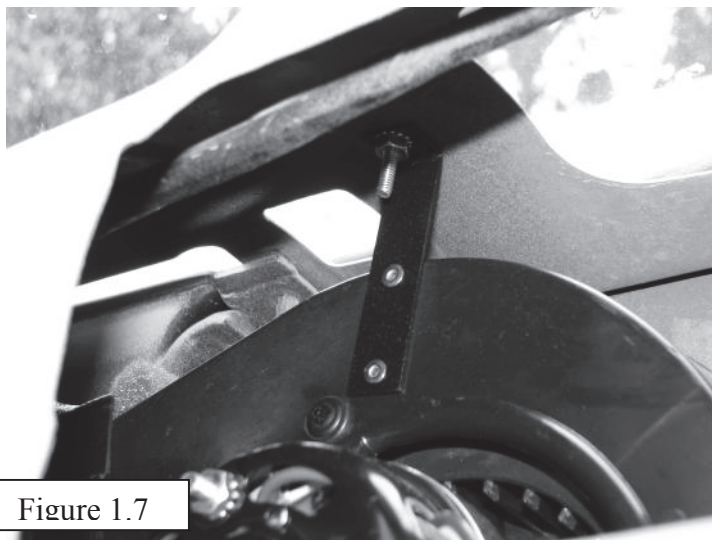

Figure 1.4

- 13) On the top of the opposite side of the evaporator is a Z-shaped bracket that will be mounted to the top of the dash. Use the 10-24 x 1/2" screw and the nut to attach this bracket. You will need to drill a 1/8" hole through the dash. Hold the evaporator housing to the bottom of the dash. Make sure the rectangle outlet on the evaporator is straight and even with the metal dash opening. Mark the hole with a marker through the hole in the bracket prior to drilling the hole. After your hole is drilled, insert the screw and tighten the nut Figure 1.5 / 1.6



- 14) Once you have the evaporator secure you can mount the blower motor. The blower motor slides into the rectangle opening on the evaporator housing. It will be attached to the metal dash with one 10-24 x 1/2" screw and the nut and one self tapping waffle head screw that are provided.
- 15) Fit the blower assembly into the evaporator opening. Push the blower housing at least one inch into the evaporator housing. Use a marker to mark where the L-bracket on the top of the housing will sit against the dash board. Drill a 1/8" and use the 10-24 x 1/2" screw and the nut to affix it to the dash board.
- 16) Use one self tapping waffle head screw to secure the other end of the blower motor to the firewall. Figure 1.7 / 1.8



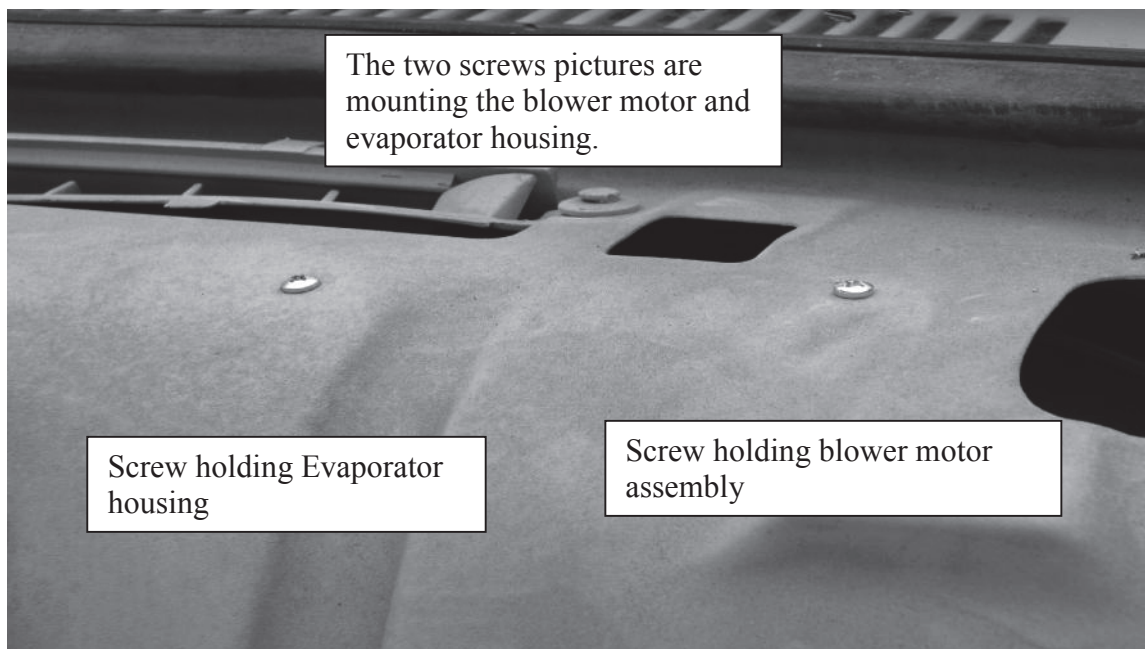

- 17) On the dash pad there is a plastic panel that sits above the glove box. This panel will need to be removed from the pad. On trucks 1980 - 1987 there is a Silverado insignia. The insignia needs to be removed and attached to the new panel. The new panel can be reinstalled into the dash pad.
- 18) The duct hose can be connected to the evaporator unit. Slide the duct hose over the duct hose outlets and use two waffle head self tapping screws to hold it. The round outlets do not require screws to hold them on.
- 19) Run the duct hose through the holes that will have vents. Leave about two to three inches of duct hose hanging out of the holes after the duct hose is pulled tight. Figure 1.9

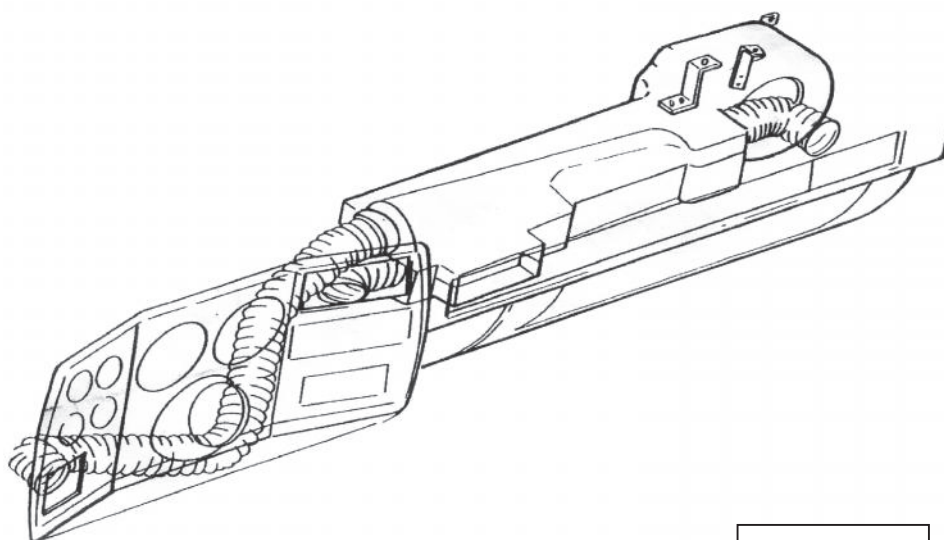

Figure 1.9

- 20) Install the dash pad onto the dash. The hose on the passenger side can be connected to the vent at this time. The round hose will squeeze over the oval hole. Make sure the center vent lines up with your evaporator unit duct opening. You may have to adjust the evaporator housing to line the louver up, if they are not lined up you will experience less vent pressure out of that vent.
- 21) Reinstall all the dash braces, steering column, and other dashboard components.
- 22) Cut the back off the instrument cluster cover pocket leaving a 3/4" flange. Secure the louver to the cluster cover.
- 23) Using the template provided on the last page of these directions cut the louver opening in the left side of the cluster cover.
- 24) Reinstall the cluster cover; secure the duct hose to the back side of the louver. Install the driver's left louver panel with four #6 3/8 screw.
- 25) The controls can be hooked up after the dash and dash components are installed.
- 26) The controls are made up of a thermostat and a fan switch. Both switches have a wire harness installed. The fan switch will turn the blower motor on and the compressor. The thermostat adjusts the temperature of the air out of the vents.
- 27) The thermostat has a silver tube coiled on it. The tube needs to be uncoiled and inserted into the top of the evaporator. The evaporator will have a small round sticker that indicates "thermostat here" on it. Be careful not to kink or break the thermostat tube. It is pressurized.
- 28) The wiring on the evaporator consists of the blower motor harness, which is three wires (red, orange, yellow). This plug will plug into the blower motor harness.
- 29) The blower will have a black wire with an eyelet; this wire needs to be grounded to a clean metal area under the dashboard of the truck.
- 30) The next wire is the 12 volt supply wire. This wire will be blue or red and will have an inline fuse. The wire needs to be connected to allow 12 volt supply when the key is on. You will need a test light to find the power source.
- 31) The final wire is the compressor wire. This wire will go through the firewall to the switch that is in the drier (high low pressure switch) then to the compressor. When hooking the wires up on the high low switch you do not have to worry about polarity. The switch is normally open, and is designed to break the power to the compressor if abnormal pressures occur.
- 32) DO NOT HOOK UP THE COMPRESSOR WIRE UNTIL THE SYSTEM IS READY TO BE CHARGED, DOING SO COULD CAUSE MAJOR HARM TO THE COMPRESSOR.
- 33) The final step is trimming the glove box. You will need to trim the glove box to clear evaporator housing. We found it easier to close the glove and see where it hits, then trim it as necessary to get it closed. By trimming a little at a time it will allow you to minimize the amount cut out of the glove box. Figure 1.10

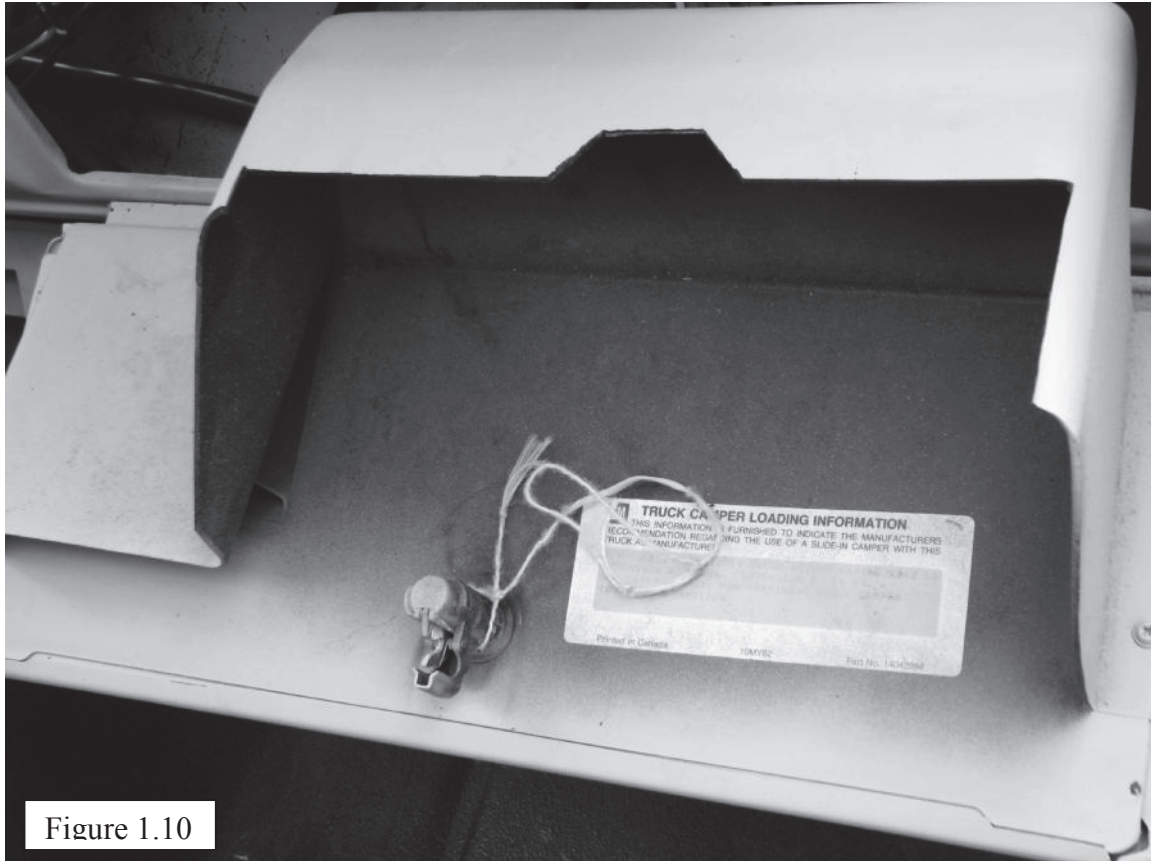

Figure 1.10

STEP TWO

Installing the condenser:

- 1) When mounting the condenser in front of the radiator, make sure the small fitting is on the bottom, and the large fitting is on the top. Use the flat brackets to install the condenser, with the included screws attach the brackets to the radiator core support and to the condenser.
- 2) DO NOT INSTALL THE CONDENSER ON THE INSIDE OF THE RADIATOR, between the motor and the radiator.
- 3) Please be sure not to puncture the condenser when installing it, there are holes designated for the mounting brackets.
- 4) The condenser should be a 1/4" to 1" away from the radiator, if more space is needed be sure to fill the sides of the condenser in with a foam fill. The object is to get a tunnel effect of air through the condenser and radiator; you do not want air to escape between the two.
- 5) Remove the radiator and fan shroud to install the radiator.
- 6) The condenser fittings have to be installed so the small fitting is on the bottom. Install the condenser so the fittings are on same side of the engine as the

compressor is mounted on. If the compressor is on the driver side, mount the condenser fittings to exit on the driver side.

Figure 2.1

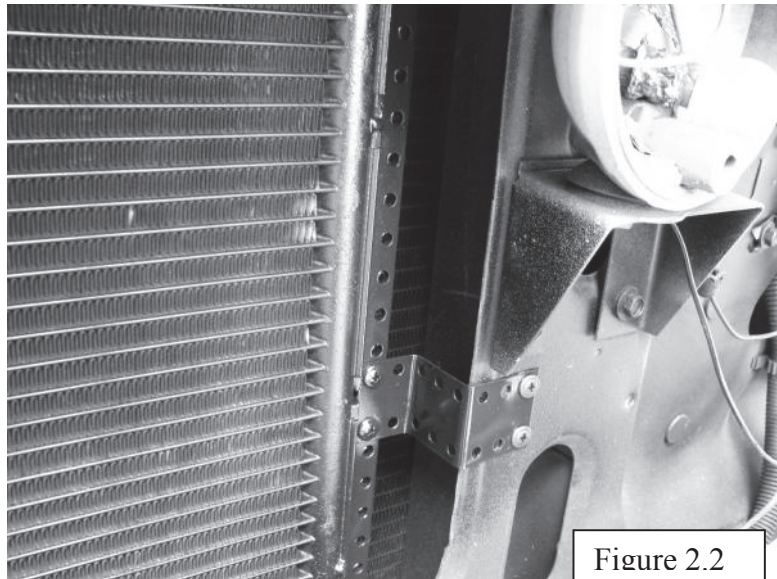
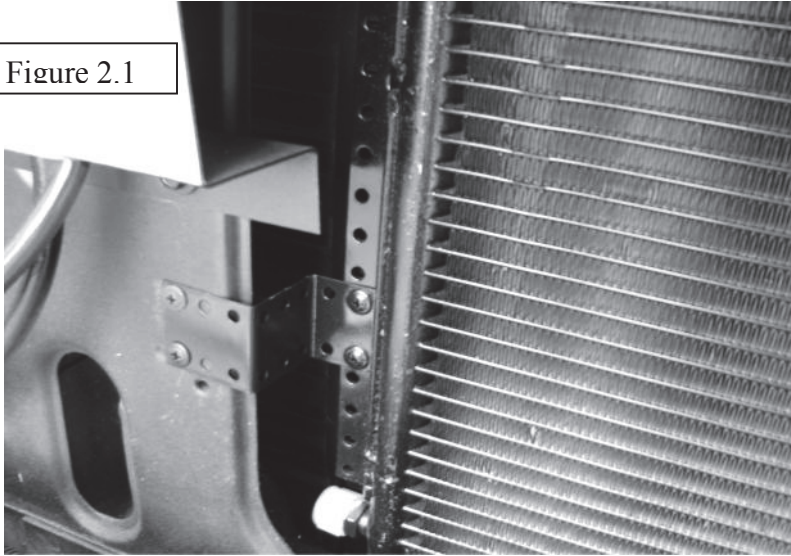
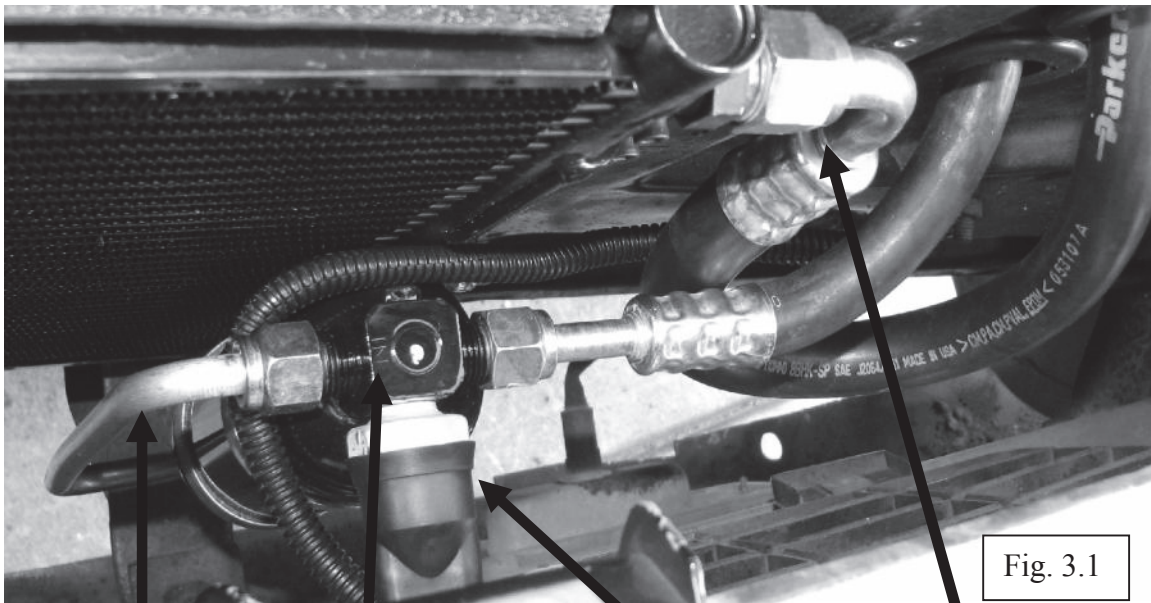

Figure 2.2

STEP THREE

Installing the drier and binary switch:

- 1) Install the drier on the same side of the engine as the compressor is mounted. This allows all of your hoses to run together back to the firewall.
- 2) The drier says "IN" on the top, the "IN" should be facing the front of the car; the hoses will run from the condenser "IN" the drier and out to the expansion valve.
- 3) If you are using R-134a refrigerant **DO NOT USE THE SIGHT GLASS.**
- 4) The binary switch is to be mounted in the drier. There are two plugs (hex head bolts) on both sides of the drier (some driers only have one). Unscrew one plug and install the binary into the switch port. Be sure the o-ring is on the binary switch.
- 5) The binary switch should be tightened one quarter of a turn past snug.
- 6) The binary switch is a round switch with a green boot covering the threads. We put the binary in the bag with the fittings when you purchase one of our a/c kits. Remove the green boot to install it into the drier.



Hose to bottom
of condenser

"IN" on drier

Binary pressure switch
with binary plug

Large fitting on
the condenser

Fig. 3.1

STEP FOUR

Installing the mount kit and compressor:

- 1) The mount kit will include directions for installation, please use the directions provided with the kit
- 2) When installing the bracket, leave the bolts loose until the compressor is mounted. It is very easy to crack a compressor if the bracket is not installed properly. Please tighten the entire bracket in a random order, while tightening do not put strain any one point.
- 3) When mounting the compressor be sure to make sure the hoses and charging ports clear the hood and the inner fender.
- 4) The compressor can be mounted with the fittings pointing in any direction. If the fittings are pointed at any angle lower than 45 degrees be sure to attach the crimped a/c hoses first. It is not recommended to mount the compressor on any angle over 45 degrees, only do so if the bracket is designed to fit the compressor at an odd angle. If the hoses are not attached first the oil can drain out, which can cause a system failure
- 5) THE COMPRESSOR IS FULL OF OIL NO ADDITIONAL OIL IS REQUIRED TO ANY PART OF THE SYSTEM. Attach the hoses, and leave the oil alone, don't add any oil to any part of the system. If oil is added the system could have many problems. A few are a sour milk smell from the vents, improper cooling, low side pressure is low, expansion valve failure, and a noisy compressor.

STEP FIVE

A/C hose routing and installation:

- 1) The a/c hoses are to be crimped with an a/c hose-crimping tool. Most a/c stores and some auto parts stores have crimping tools. The hoses can be hooked up in any order you choose. The hose kit is a universal hose kit there will be left over fittings and hose when the job is done. The charge ports are normally attached to the compressor fittings. They do not have to be put on the compressor; it is up to the installer. Prior to having the hoses crimped together. Put the fittings on the hose with masking tape around each end to mark with a marker for clocking. Do not crimp the fittings over the tape.
- 2) The two hoses that connect to the evaporator will run under the factory heater box and out through the firewall. Figure 5.1

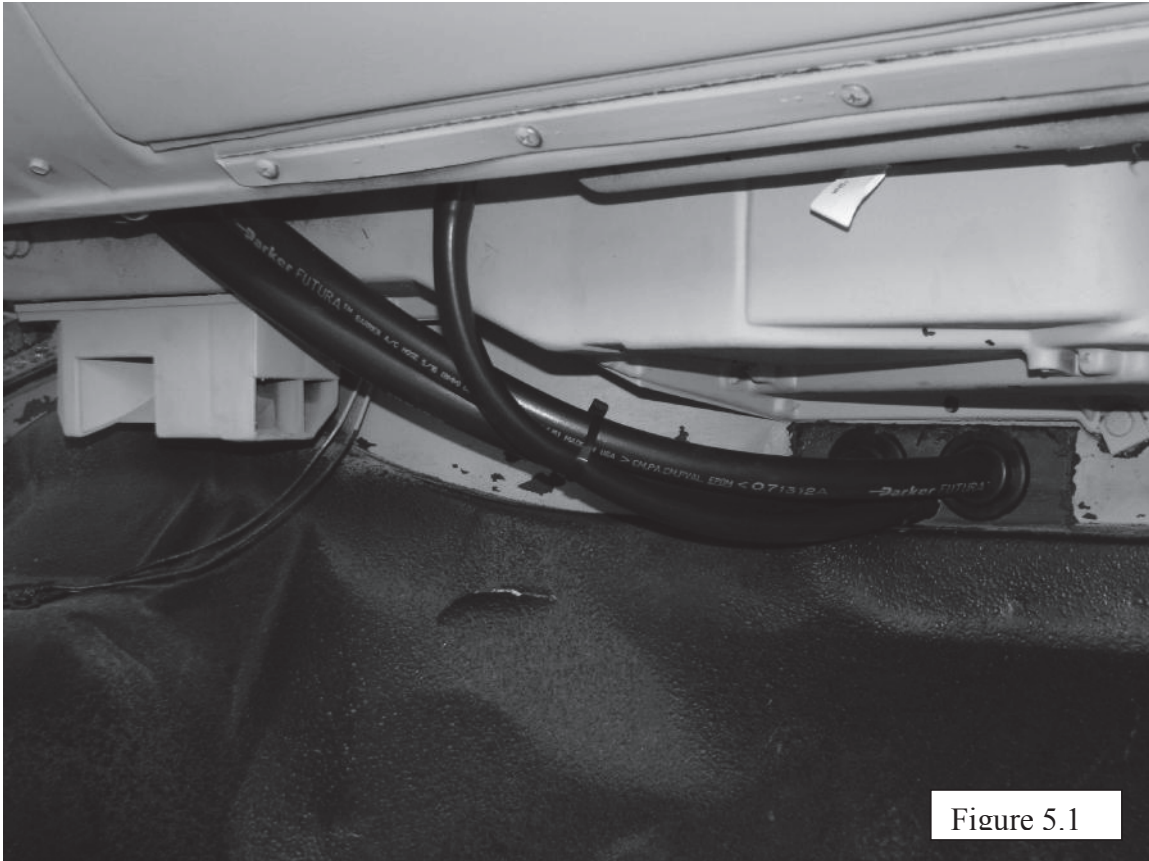

Figure 5.1

- 3) Starting with the large hose #10 or 1/2". This hose goes from the large fitting on the compressor to the evaporator unit. The compressor will get the fitting with the charging port, low side. This hose will run through the firewall so be sure to use a grommet, 1-1/4" hole required.
- 4) The next size hose is #8 or 13/32". This hose runs from the compressor to the condenser. The compressor will get the fitting with the high side charging port. The condenser fitting connects to the fitting at the top of the condenser. When running the hose through or around the core support make sure it is protected with loom. A hole can be rubbed into the hoses if the hose is against metal edges.
- 5) The third and fourth hose to install is the # 6 or 5/16" hose. Start with the # 6 hose that runs from the bottom fitting on the condenser to the "IN" fitting on the drier. From the drier the hose will go through the firewall and grommet, 1-1/4" hole, to the expansion valve on the evaporator. After this hose is attached, place the black insulation tape over the fittings that are attached to the evaporator. Keep the #10 and #6 hoses close together when routing through the firewall, it makes the evaporator installation process easier.
- 6) The fittings included with the hose kit can be used in any manner necessary to run the hoses without kinking the lines. Make sure the hoses do not rub on metal edges without protection, and be sure to put O-rings on all the fitting connections. Oil is not necessary on the O-rings; it can be added to the threads on the fittings to stop them from seizing. DO NOT USE TEFLON TAPE. Tie the hoses down from flopping around, and keep the hoses off of the exhaust.

STEP SIX

Installing the drain tube:

- 1) The drain tube goes from the drain outlet on the evaporator through the floorboard of the vehicle. The hole should be $\frac{3}{4}$ " and the drain tube should be straight without any kinks. Do not let the drain hose rub on any sharp edges that can cut a hole in it.
- 2) Run the drain tube so it exits the firewall near the a/c hoses. Make sure the drain will not drip on any exhaust pipes.

STEP SEVEN

Charging the system:

- 1) DO NOT ADD OIL TO ANY PART OF THE SYSTEM. DO NOT USE DYE, LEAK SEALANTS, OR ALTERNATIVE REFRIGERANTS IN THE SYSTEM. We are not able to diagnose problems if the directions are not followed.
- 2) The system should be evacuated in order to achieve maximum cooling from the system. Evacuate the system for 45 – 60 minutes. If the system is not evacuated the system may not cool properly.
- 3) After the system is evacuated and ready to charge, plug the compressor wire in.
- 4) When charging the system start with 1.53 LBS of R-134a refrigerant (two cans). The ideal pressures of the system are 15-28 on the low side and 180-220 on the high side. If the system is not within this range with 1.5lbs of R-134a add more R-134a in .25LB increments. If the high side gets high, and the low side stays low you have a condenser-cooling problem. Please see the first page.

Simulated Diagram

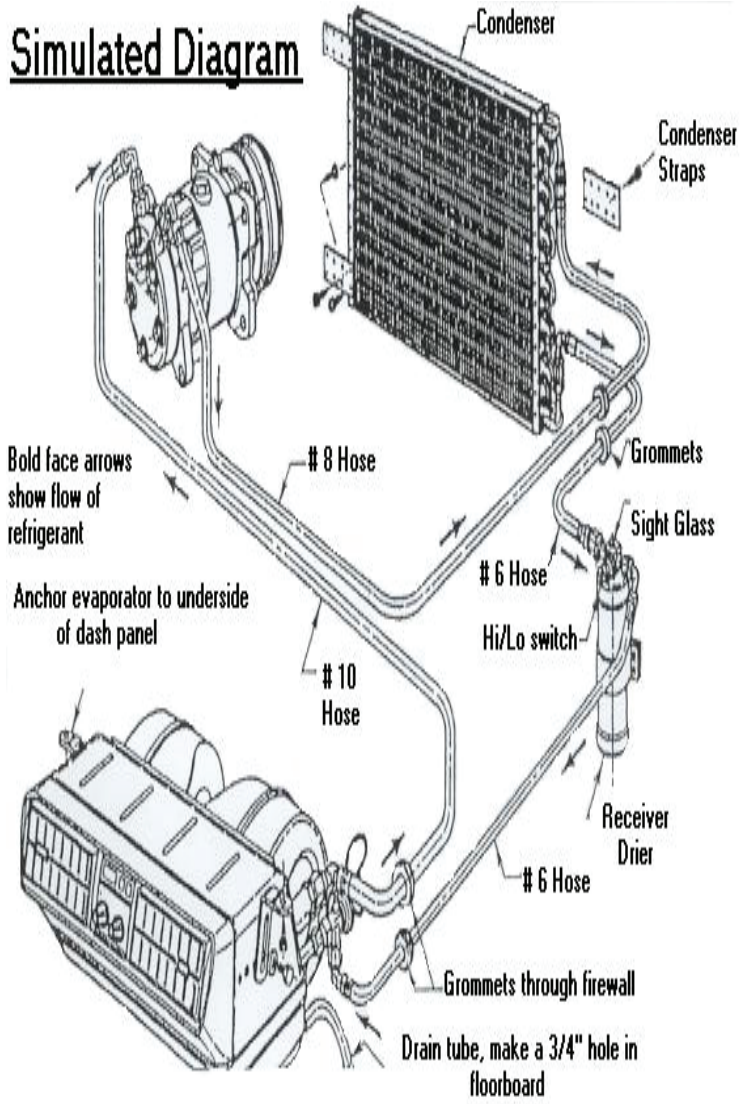

Wiring Diagram

